

# UPPER

## Automatismo para Portões de Garagem

### Installation Instructions & User Guide

 **UPPER 600** **UPPER 1000** **UPPER 1200**

### **WARNING**

Please read this manual carefully before you begin installation or use. Your new door opener should only be installed by a qualified or licensed professional. Attempting to install or repair the door opener without proper technical training could result in serious injury, death, and/or property damage.

Safety Guidelines	°	ç
Getting Started: Basic Functions	°	“
Installation	°	·
Installation (Full Steel Rail)	°	^
Installation Tips	°	~
Setting Up Basic Functions	ç	°
Overview of Advanced Features	ç	”
Wiring Guide	ç	^
Manual Disengagement	ç	~
Maintenance	ç	~
Manufacturer's Statement	ç	
Final Notes	ç	
Technical Specifications	ç	
Kit Components	ç	~
General Errors / Codes	°	
WiFi Connection Guide	ç	

## Essential Safety Recommendations

The new GDO (Garage Door Opener) features a professionally crafted design inspired by the latest trends. Installing and setting up this GDO is incredibly straightforward. With a full suite of functions, it offers users a smooth and enjoyable installation experience.

## Safety Notices

Notice: Be sure to read these safety warnings and follow all instructions before starting installation. Failure to do so may result in serious personal injury and/or property damage. Keep these instructions on hand.

This device may be used by children above a certain age and by individuals with limited physical, sensory, or mental abilities, or those with less experience or knowledge, as long as they are supervised or have been instructed on safe usage and understand the associated risks. Children should not play with the device or its controls, including transmitters. Keep transmitters out of reach of children. Cleaning and maintenance should not be performed by children without supervision.

We highly recommend installing a photocell to enhance both protection and peace of mind.

Before installing the unit, be sure to remove any unnecessary ropes or chains and disable equipment such as locks that aren't needed for automatic operation. Make sure the door is mechanically sound, properly balanced, and opens and closes smoothly.

Weighted sound pressure level A for the drive mechanism  $L_{pA} \sim 65$  dB(A).  
The operator should not be used on doors that lack a safety lock.

Install the manual release mechanism at a height below 1.5 m. If it's removable, keep it stored right next to the door.

Any fixed control should be installed at a height of at least 1.5 m and placed where it's visible from the door, but away from moving parts.

Install the wall switch or wall transmitter out of reach of children.

Permanently affix entrapment warning labels in a prominent location or close to any fixed controls.

Permanently place the manual release label next to its operating part.

After installation, make sure the mechanism is properly set and the drive reverses or releases if the door contacts an object of 25 mm height placed on the floor. Ensure no part of the door extends onto sidewalks or public roads. See pages 17 - 18 for guidance on adjusting the door and drive.

Connect the GDO to a 230V AC circuit, and secure it in place by a qualified professional.

**WARNING:** Disconnect the drive from its power source during cleaning, maintenance, or when replacing parts.

Electrical products shouldn't be thrown out with regular household trash. Please recycle them at designated facilities. For guidance on recycling, reach out to your local authority or retailer.

If the power cord is damaged, it should be replaced by the manufacturer, a service agent, or a qualified professional to prevent hazards.

Keep an eye on the moving door and make sure everyone stays clear until it is fully open or closed.

Use caution when operating the manual release, as an open door may drop quickly because of weak or broken springs or if the door is unbalanced.

Regularly inspect the door, especially the cable, springs, and parts attached to the wall. Do not use the door if it needs repair or adjustment, as improper installation or poor balance can cause injuries. If door components are under high pressure, do not attempt repairs yourself—call an authorized service provider if needed.

Check every month to make sure the unit reverses or releases objects when the door touches something placed on the floor with a height of 50 mm.

The unit must not be used with a door that has a small access door, unless the unit cannot operate when the small door is not secured in the safe position.

If applicable, do not use the unit with doors that have openings larger than 50 mm in diameter or with edges or protruding parts where someone could grab or stand.

Do not open or close the door when people are nearby. Always keep children away from moving doors. Failure to do so may result in serious personal injury and/or property damage.

To keep the unit safe from rain, do not expose it outdoors. Never submerge the unit in water, spray water on it, or place it near any device containing water.

For the unit to detect objects under the door, the door must press against the obstacle. This may cause injury or damage to the object, the door, or a person.

If the circuit is damaged, repairs must be performed by a qualified professional.

Make sure the garage door is fully open and stopped before entering. Make sure the garage door is completely closed and stopped before leaving.

This device is designed for opening and closing tilt-up and sectional residential garage doors.

For 100N, best suited for doors under 2.0m and 20kg.

For 150N, ideal for doors less than 2.0m and 20kg.

For 200N, recommended for doors up to 2.0m and 20kg. For 250N, suitable for doors up to 2.0m and 20kg. For 300N, perfect for doors under 2.0m and 20kg.

This device is intended for use only with private garage doors in single-family homes and is not for commercial applications.

The device should be installed indoors, at a maximum distance of 1.5m from the door and at least 0.5m from the garage ceiling. Please refer to the installation instructions for further details. Improper use of the unit may increase the risk of accidents.

# Introduction to Basic Functions

**Smooth Start & Stop** Reduces strain on the garage opener and door during operation.

**Automatic Closing Feature**

**Remote Lock Feature**

**Automatic Reversal**

If the door encounters an obstacle while opening, it stops immediately. When closing, it will stop and then reverse by 10cm.

**Partial Opening Feature**

**Vacation Mode**

**Dynamic Force Self-Learning** Ensures the garage door motor runs smoothly, adapting to changes in door resistance caused by seasonal shifts.

**Partial Opening Feature**

**Vacation Mode**

**Adjustable Automatic Reversal Force**

Wide adjustment range for reliable and sensitive operation.

**Door Opening Mode**

**Color Light Mode**

Requires connection to lighting (not included).

**Overload Detection**

If overloaded while closing, the door will automatically reverse by more than 10cm; if overloaded while opening, it will stop.

**Backup Battery Output Terminal**

**Wall Switch Output Terminal**

**High/Low Voltage Protection** The system won't open or close if the voltage is too high or too low, helping prevent damage to the door panel and controller.

**Photocell Output Terminal**

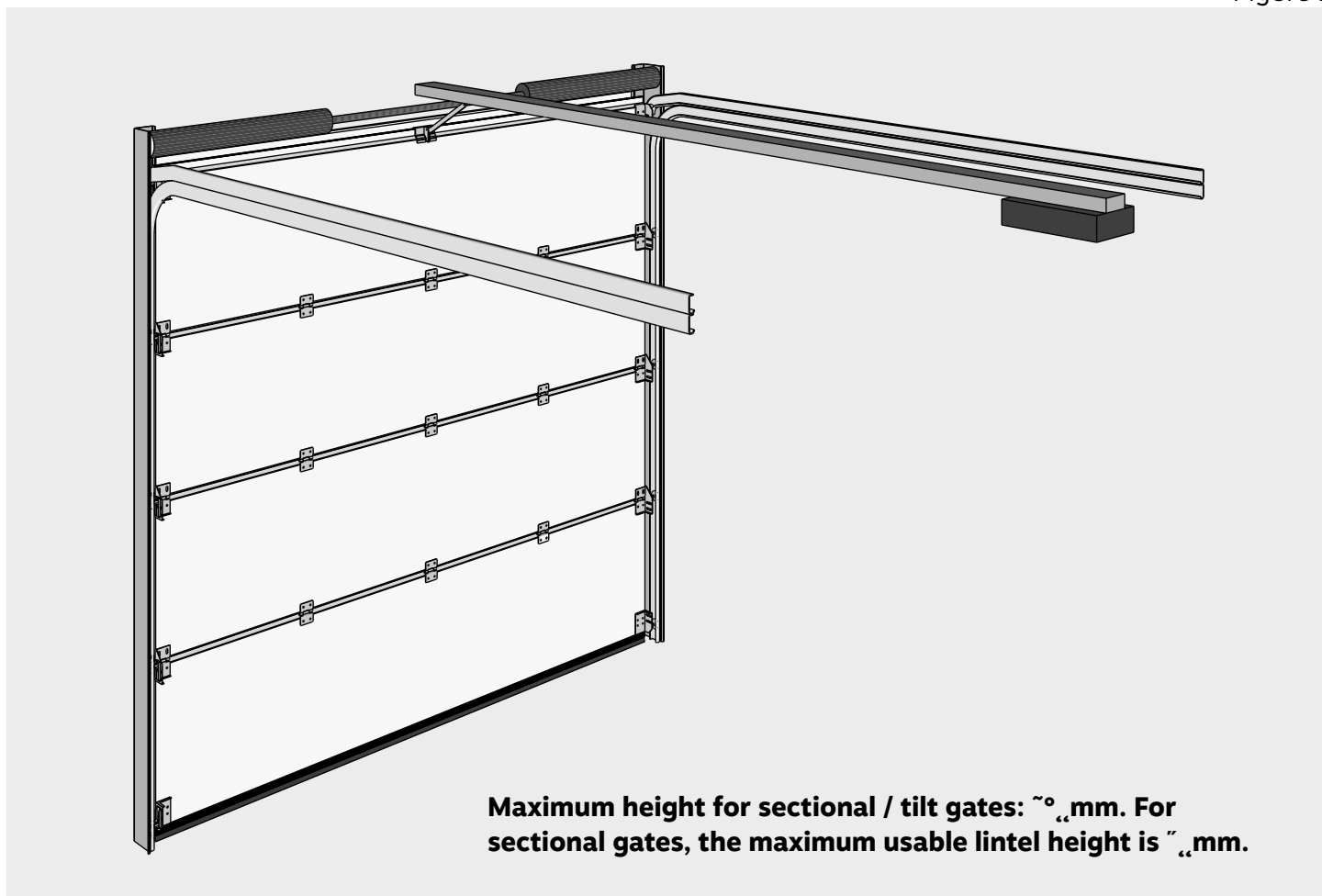
**Pedestrian Door Safety Output Terminal**

**Rolling Code Transmitter** With millions of unique codes, you're protected from code duplication and hacking.

**External Receiver Output Terminal**

# Installation

Figure 2



1. Please read the instructions carefully.

2. Make sure the gate's framework is sturdy and suitable for motorization.

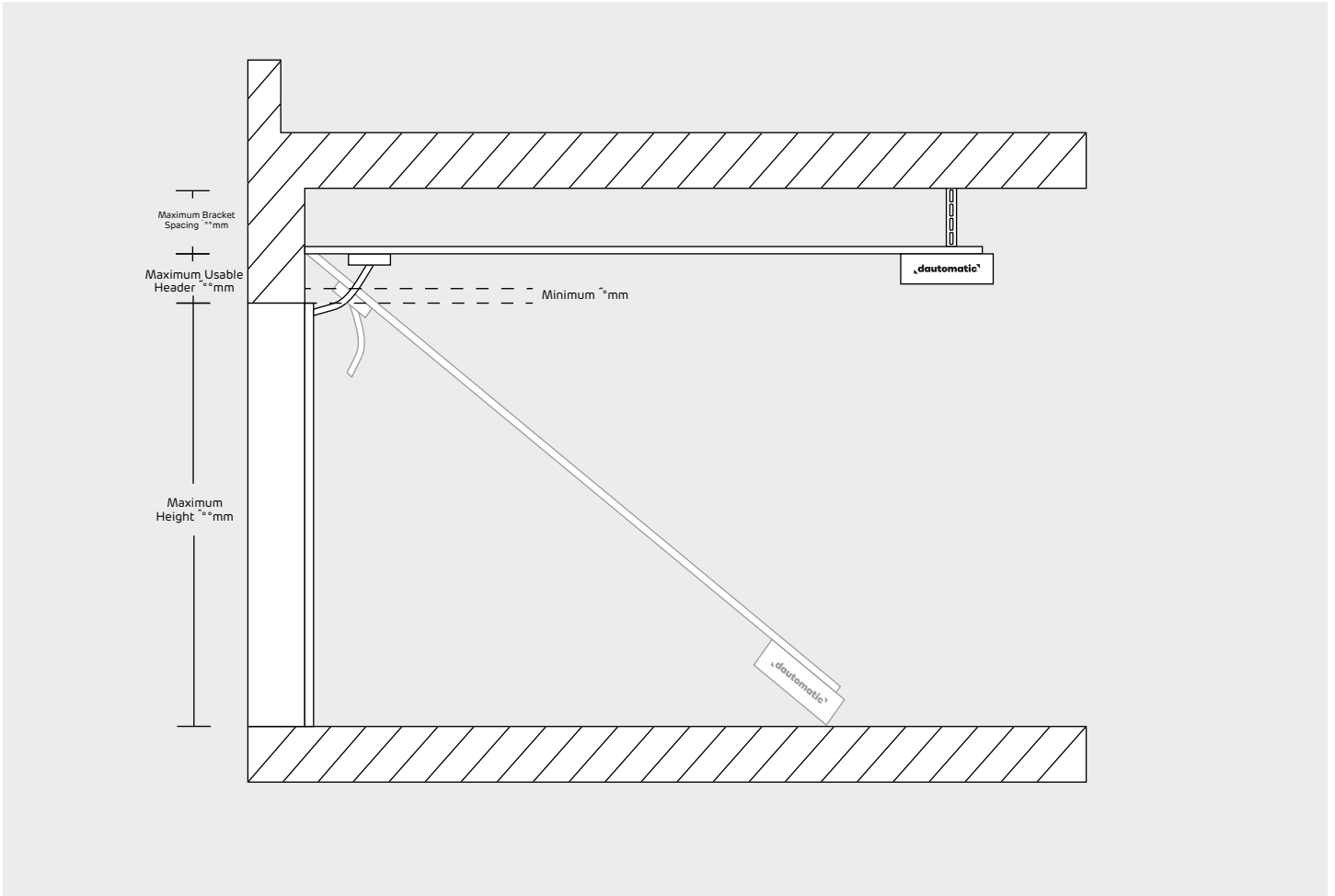
3. Ensure there are no friction points when the gate is moving.

4. The gate must be properly balanced and should be easy to raise and lower by hand.

5. Install a protected 220-240V outlet close to where the automation system will be placed.

# Installation

Figure



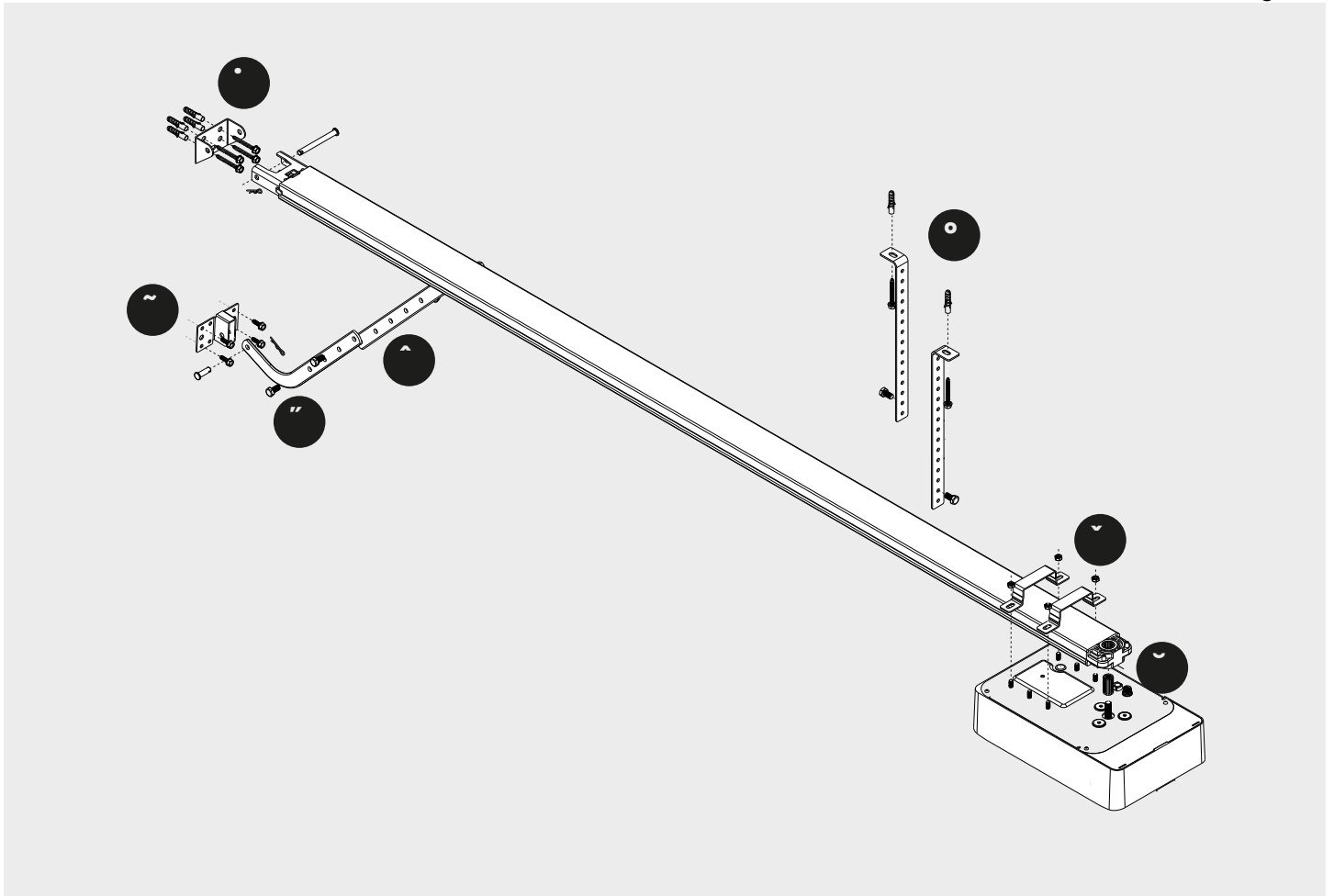
Keep at least  $\sim$ mm of clearance above the maximum height of the top panel.

Make sure the track is both level and aligned vertically. Check that the connection between the hanging bracket and the ceiling is secure and stable.

**Warning:** Ensure the opener is mounted to the ceiling reinforcements, not to drywall. Failure to achieve a secure and firm attachment could result in the opener falling, which may cause serious injury or damage.

# Track and Accessories

Figure 1



1. Wall Bracket

2. Panel Mount

3. Folding Arm

4. Straight Arm

Ceiling Mount Brackets

5. Track Brackets

6. Motor Shaft Adapter (for track)

# Installation Procedure

**1. Mounting the wall bracket.**

Secure the wall bracket to the wall, positioning it 10 cm-15 cm above the axis or intermediate bracket, depending on your actual installation space.

**2. Attach the steel rail to the wall bracket using a dowel.**

If using a belt rail, continue to step 3. If using a chain rail, skip to step 4.

3. Fit the motor shaft adapter onto the motor shaft as shown in the diagram. Note: Make sure the flanged end is facing downward.

4. Attach the garage door opener to the rail using the U-shaped bracket A. A tightening force of 10 Nm is sufficient.

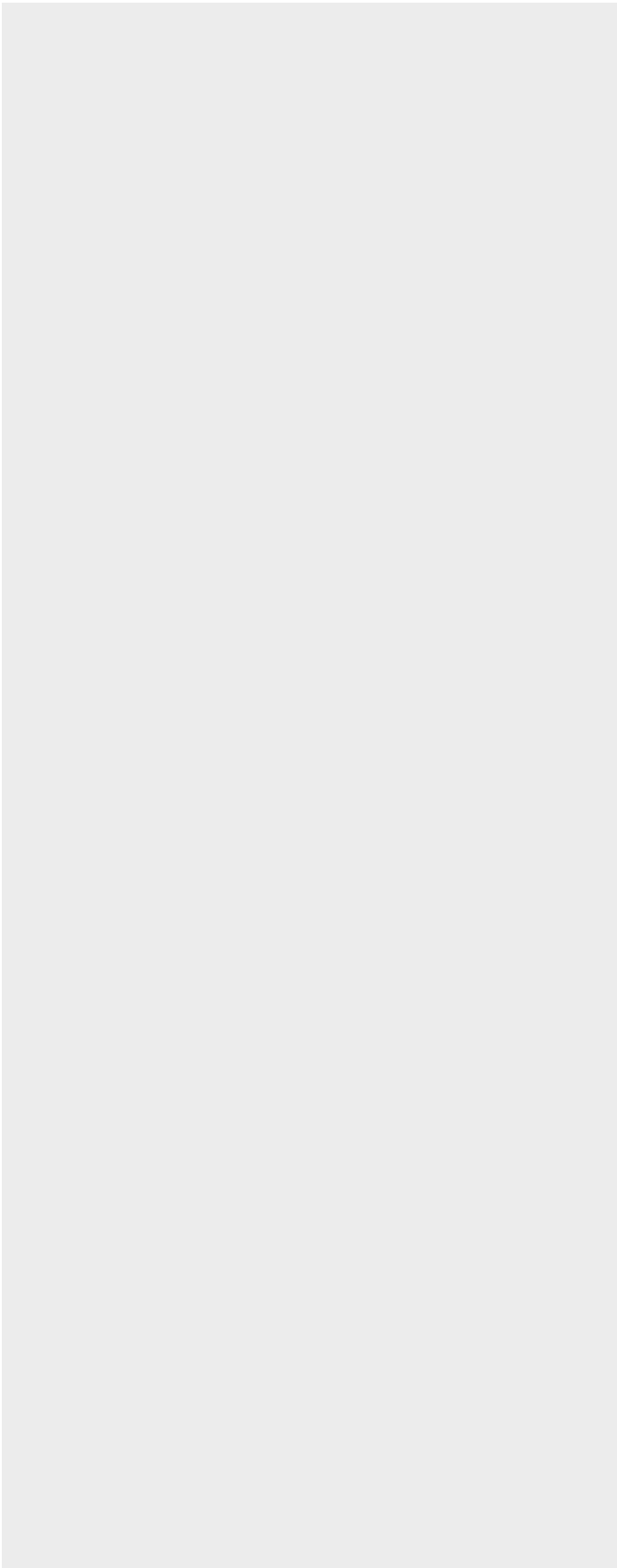
5. Secure bracket A to the base plate of the garage door opener, then hang the rail from the ceiling using iron bracket A. Make sure the connection between iron bracket A and the ceiling is strong and stable.

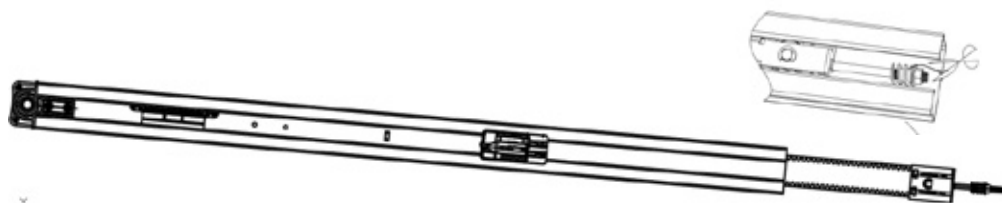
6. Attach the gate bracket to the panel, install both the straight and bent arms, and secure the clutch cord.

7. Release the clutch and try opening and closing the door by hand. Make sure there's no friction between the door panel and the rail.

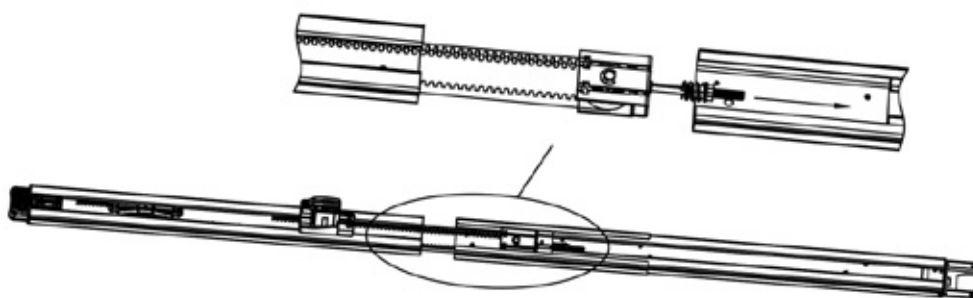
8. Connect the automation system to the power supply and configure the operation.

**Warning: Make sure the opener voltage matches your local voltage. Connect the opener to a properly grounded power source.**

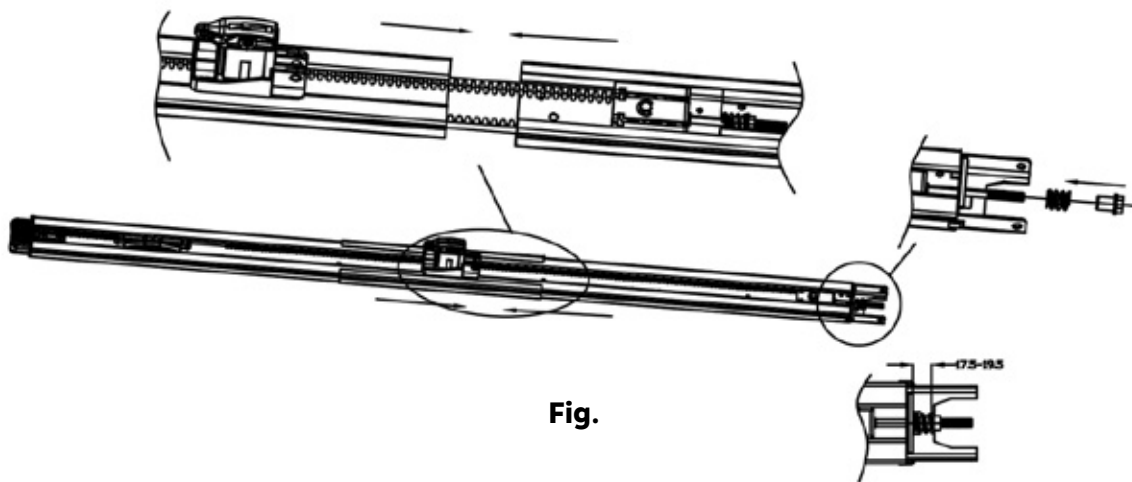




**Fig. 1**



**Fig. 2**



**Fig. 3**

\*\*As shown in Fig. 1, cut the plastic clamp on threaded rod "A" and pull threaded rod "A" along with the inner belt toward the sleeve.\*\*

\*\*As shown in the figure, install the clutch.\*\*

\*\*Refer to the illustration: connect both rail pieces to the sleeve, then tighten the nut in the correct position as shown.\*\*

# Installation Guidelines

Mounting the wall bracket. Attach the wall bracket to the wall at a height of  $cm - cm$  above the axle or intermediate support (based on the actual installation space).

Secure the steel rail to the wall bracket using a split pin.

If your rail uses a belt, continue to step  $\sim$ . If it uses a chain, skip ahead to step  $\cdot$ .

Fit the motor shaft adapter onto the motor shaft as shown in the diagram.

**Warning: The flanged end must be facing downward.**

Secure the garage door opener to the rail using the U-shaped bracket A. A tightening force of  $Nm$  is sufficient.

Attach angle A to the base plate of the garage door opener, suspending the rail from the ceiling with iron angle A. Make sure the connection between iron angle A and the ceiling is firmly secured.

Attach the door bracket to the door panel, secure both the straight and curved arms, and fasten the clutch cord.

Release the clutch and test opening and closing the door by hand. Make sure there's no friction between the door panel and the track.

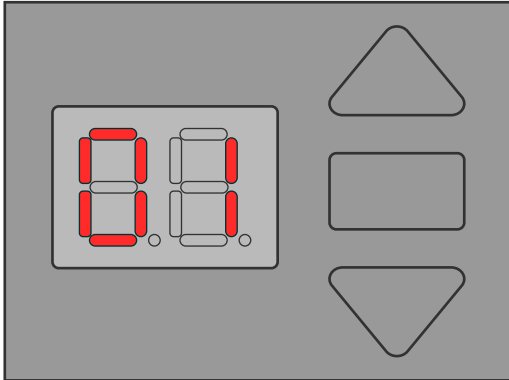
Connect the opener to power and adjust its operation.

**Warning: Make sure the opener's voltage matches the local supply. Connect the opener to a properly grounded power source.**

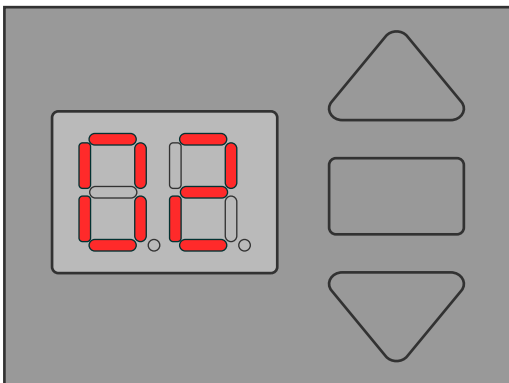
# Basic Functions Setup

You can also use an app to set up all the features

## 1. Limit Setting for Opening and Closing with Dynamic Auto-Learn Force



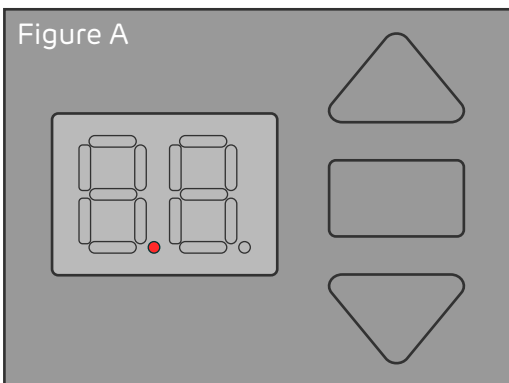
Press and hold the 'SET' button until the LED displays '0'. Next, set the upper limit by pressing the 'up' button. Use 'UP' or 'DOWN' for precise adjustments and confirm the final position of the upper limit, then press 'SET' for the display to automatically switch to '0'. Now, set the lower limit by pressing the 'down' button. Use 'UP' or 'down' for fine-tuning and confirm the final lower limit position, then press 'SET'. The opener will automatically cycle to memorize the limit positions and the opening/closing force.



'--' on the display means the opener does not have a travel limit set.

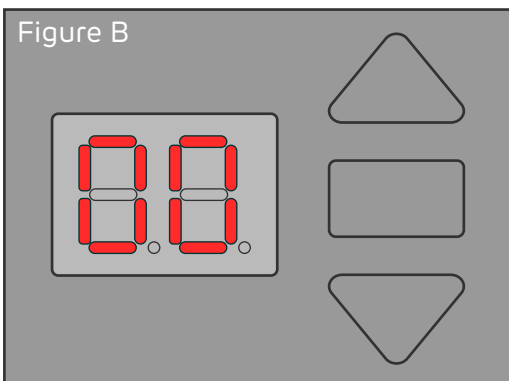
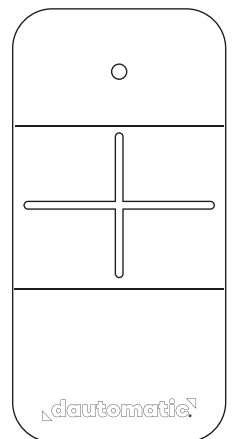
'FF' on the display shows the opener has finished setting the travel limit.

## 2. Storing and Erasing Commands



### Add Commands

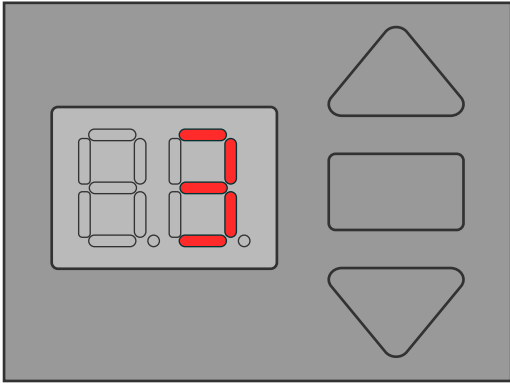
Hold down the 'UP' button until the LED dot starts flashing. (See Figure A) Next, press any button on your remote control twice; the LED dot will blink rapidly, then turn off, signaling that the command has been successfully programmed. You can now use the remote to open, close, or stop the motor.



### Delete all commands

Press and hold the 'UP' button for a few seconds (the LED dot will start flashing) until the LED display shows '00'. This will erase all stored codes.

**7. Safety Reverse Force Adjustment**

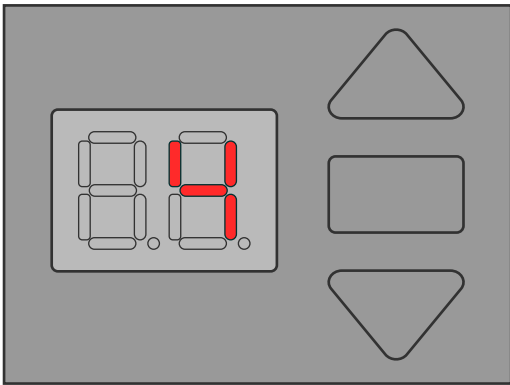


Press and hold the 'SET' button until the LED displays '9'. This puts the system in force adjustment mode. The LED will show you the current force level.

Use the 'UP' button to increase the force level, or the 'DOWN' button to decrease it.

**Note: The maximum force level is 9, and the minimum is 1. Make sure the photo beam is properly connected and working before selecting a level between 1 and 9. Otherwise, you can only choose between 1 and 9.**

**8. Automatic Closing Settings**



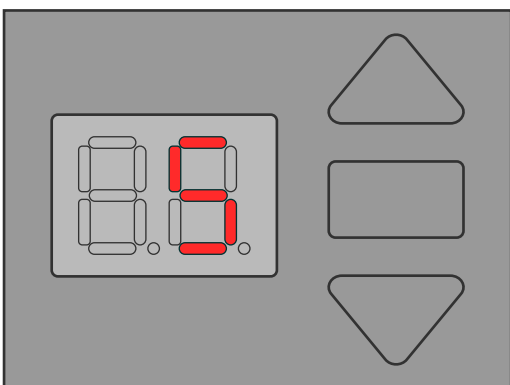
Press and hold the "SET" button until the LED shows "9". Press the "UP" button to increase the auto-close time, or "DOWN" to decrease it. Press 'SET' again to save your settings. When auto-close is enabled, the fully open door will close automatically after the set time.

The auto-close function will turn off when the LED displays 0.

The number 1 = 10 seconds, 2 = 20 seconds, 3 = 30 seconds... the maximum value is 9 = 90 seconds.

**Attention: The photocell must be installed and activated first. Otherwise, the automatic closing feature cannot be set up.**

**9. Photocell Setup**



Press and hold the 'SET' button until the LED displays the number '9'.

Press the 'UP' button until the LED shows '1', enabling the photo beam function.

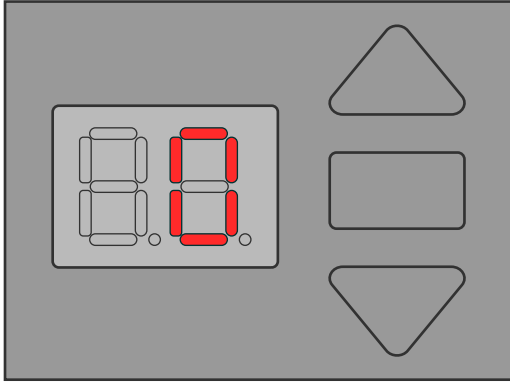
Press the 'DOWN' button until the LED displays to disable '0' to this function.

Press 'SET' to save your settings.

Make sure the connected infrared sensor is operated by a pulse-controlled photo beam, and that the wiring matches Figure 1.

**Notice: If the photo beam feature is turned on but the beam itself isn't connected, the door will not close.**

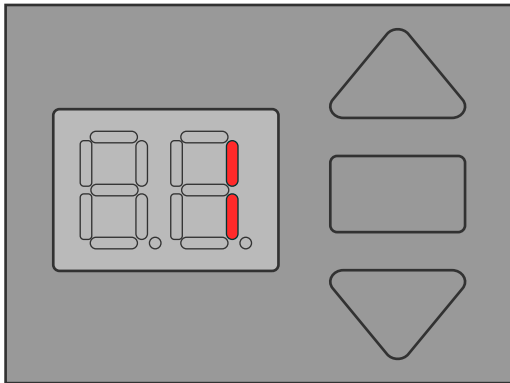
**WiFi Settings**



Hold down the 'DOWN' button until the LED displays the number '01'.

Press the 'UP' button to select a setting: '0' lets you enter WiFi connection mode. Press 'SET' to begin connecting to WiFi.

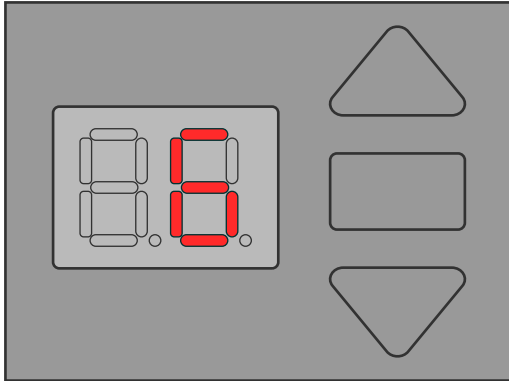
'1' indicates a WiFi reset. Press 'SET' to confirm once the reset is complete. All connected devices will be removed.



For more detailed instructions, please refer to the WiFi user manual.

# Overview of Special Features

## 1. Dynamic learning for partial opening function.

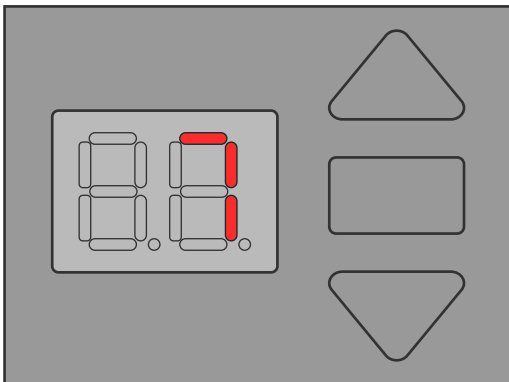


Hold both the 'UP' and 'DOWN' buttons at the same time until the LED displays '°^'. Next, press "SET". Use the 'UP' or 'DOWN' button to adjust the partial opening height.

The symbol  $\frac{1}{2}$  stands for  $\frac{1}{2}$ °cm, the number  $\frac{1}{4}$  means  $\frac{1}{4}$ °cm,  $\frac{1}{8}$  means  $\frac{1}{8}$ °cm... and  $\frac{1}{16}$  represents  $\frac{1}{16}$ °cm, continuing on in this way. Press 'SET' to save your setting.

If the LED displays '°', the partial opening feature is turned off. The partial opening distance cannot exceed the full opening distance.

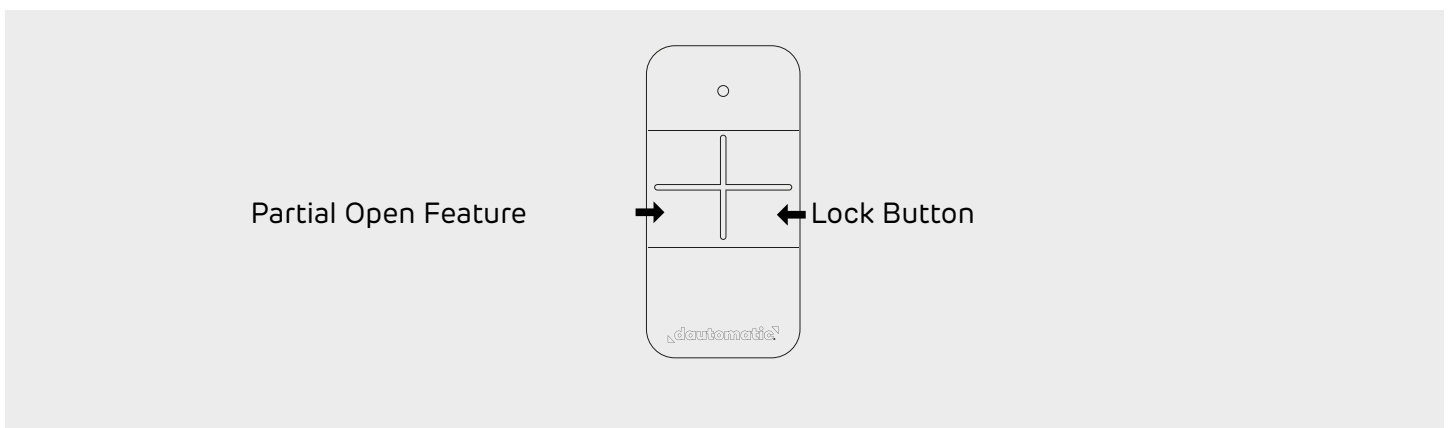
## 2. Lock Button on the Transmitter



Press and hold the 'UP' and 'DOWN' buttons together until the LED shows '°^'. Then press 'UP'; the LED will display '°^'. Press 'SET' to confirm the lock button setup mode. Next, press the 'UP' button again and the LED will show ' $\frac{1}{2}$ ', indicating the lock button is enabled.

Press the 'DOWN' button; when the LED displays '°', the lock button is deactivated. Press 'SET' to confirm.

Once setup is complete, the programmed button on the transmitter will be disabled a few seconds after the door fully closes. To operate the door opener, press the unlock button on the transmitter first, then press the programmed button.



## 2. Flashing Light Feature (Beacon)

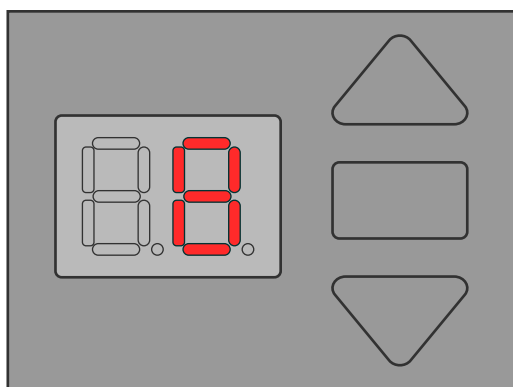
Dedicated connections are available for this function and provide a flashing light voltage of  $\sim 5-12V$ . Connect the beacon using DC  $\sim 5V$ , with a current of  $\sim 100mA$  (see Fig. 2).

If you're using flashing lights powered by AC  $\sim 220V$ , please pair with an adapter and wire as shown (see Fig. 1).

## 3. Pedestrian Door Protection (SD)

This feature ensures the gate won't open unless the pedestrian door is closed, helping to prevent panel damage. Connect as shown in Fig. 2.

### 1. Door Opening Mode

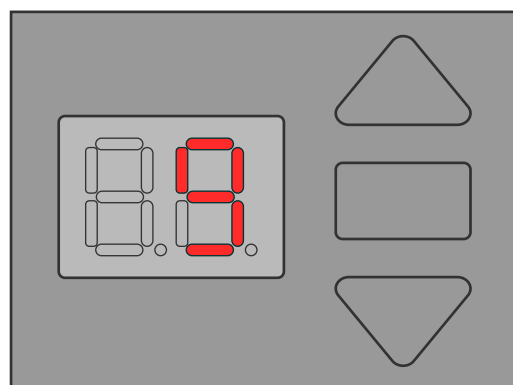


Hold down both the 'UP' and 'DOWN' buttons until the LED displays '8'. Next, press 'UP' until the LED shows '8'. Press 'SET' to confirm the single door opening mode.

Then, press the 'UP' button. The LED will show '8', indicating this mode is active.

Press the 'DOWN' button. The LED will display '0', which means the mode is now deactivated. Press 'SET' to confirm.

### 2. Closing Speed Selection Mode



Hold down both the 'UP' and 'DOWN' buttons until the LED shows '8'. Then, press 'UP' until the LED displays '8'. Press 'SET' to confirm the mode.

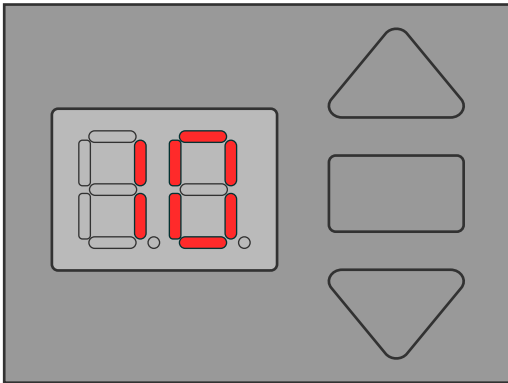
Next, press the 'UP' button. The LED will show 'L', meaning normal closing speed is selected.

Press the 'DOWN' button and the LED will display 'H', indicating the high-speed closing mode. Press 'SET' to confirm your selection.

**Note: High-speed closing mode is only available for motors equipped with the high-speed version.**

The photo beam must be installed and activated first. Otherwise, you won't be able to choose the closing speed.

**Light Bar Function**

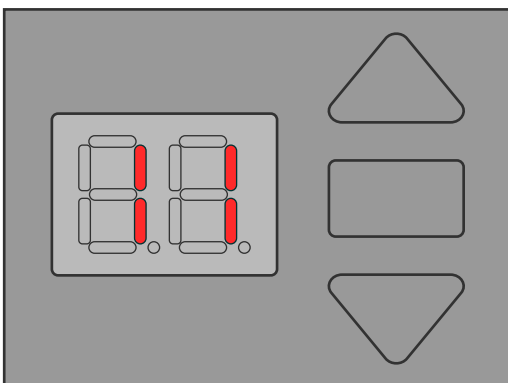


Hold down the 'UP' and 'DOWN' buttons together until the LED displays '0'. Then, press 'UP' until the LED shows '1'. Hit 'SET' to lock in your selection.

The LED will display 'L'. Next, press 'UP' and the LED will show 'L'. Press 'UP' again and you'll see 'L'. Keep pressing to cycle through until you reach 'L'. Pick any color you want and press 'SET'. There are six different colors to choose from.

**Note: This feature is only available when the light bars are installed.**

**Vacation Mode**

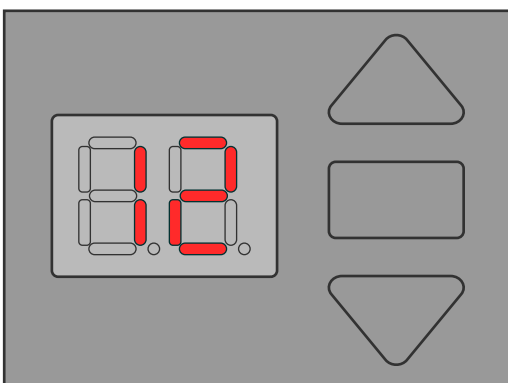


Press and hold both the 'UP' and 'DOWN' buttons until the LED displays the number '0'. Next, press 'UP' until the LED shows '1'. Press 'SET' to confirm your selection.

The LED will display '0'. At this point, vacation mode is turned off. Then, press the 'UP' button and the LED will show '1'. Press 'SET' to enable vacation mode.

**Notice: When vacation mode is active, external controls and keypads cannot unlock the door.**

**Party Mode**



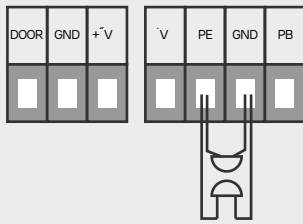
Hold down both the 'UP' and 'DOWN' buttons until the LED displays '0'. Next, press 'UP' until you see '1'. Hit 'SET' to confirm the mode. The LED will show '0'. The party mode is now turned off.

Now press 'UP' and the LED will show 'P'; press it again to see 'P'. Keep pressing to cycle through 'P'. There are three party modes to choose from. Pick any mode you want and press 'SET' to select.

**Note: This feature is only available when the light bars are installed.**

# Wiring Guide

Figure 2



Photocell Connection

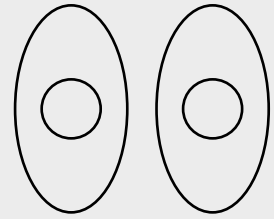
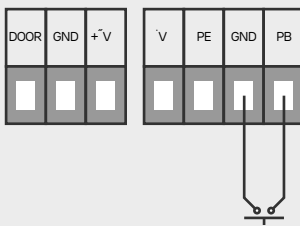


Figure 3



Wall Push Button Wiring

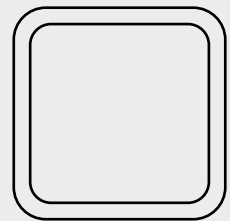
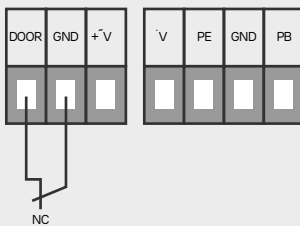


Figure 2



Man Door Connection

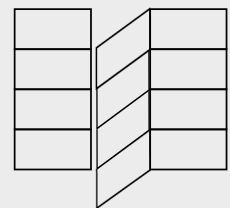
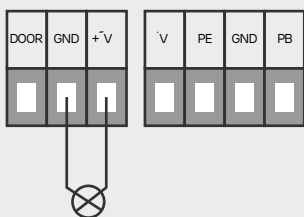


Figure 4



Warning Lamp Wiring

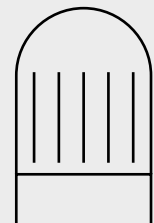
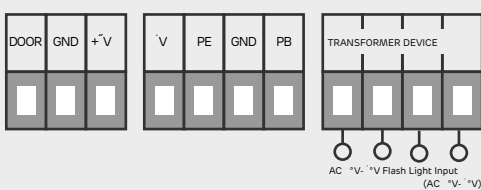
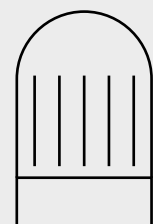


Figure 5



Beacon Connection  $\sim$ °V



# Manual Release

The system includes a manual release cable, allowing you to disengage the shuttle and operate the door by hand while holding the handle down (see Fig. 4).

Pull the handle to disconnect the shuttle. To re-engage, simply run the opener in automatic mode or manually move the door until the carriage locks back into the chain shuttle.

In some cases where a pedestrian door is not present, it is recommended to install an external release device (see Fig. 5).

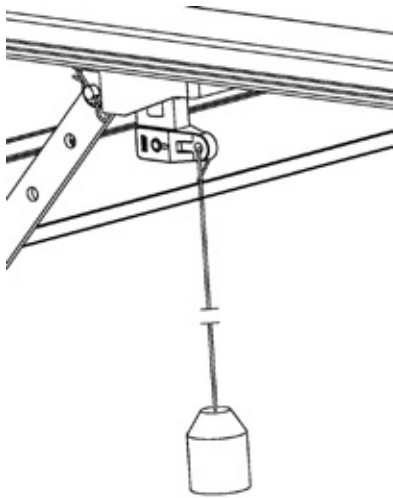


Figure 4

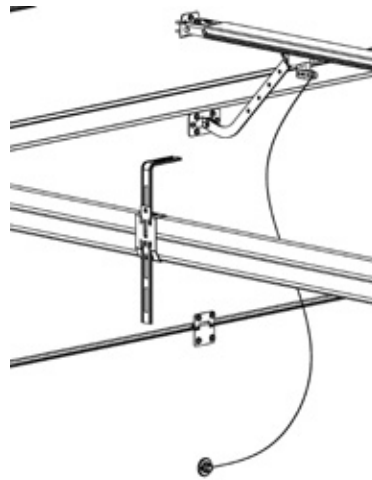


Figure 5

# Maintenance

No special maintenance is required for the logic circuit board.

Inspect the door at least twice a year to ensure it's properly balanced and all working parts are in good condition.

Test the reverse sensitivity at least twice a year and make adjustments if needed. Make sure all safety devices, like photo beams, are operating effectively.

**Warning: If the door operates roughly, it may place undue strain on the automatic opener and could void your warranty.**

# Manufacturer's Declaration

We hereby certify that the product of this model, in terms of its design, construction, and version, meets all essential health and safety requirements of the following CE regulations: EMC Directive and Low Voltage Directive. The detailed standards are as follows:

EN 60950-1, EN 60950-2, EN 60950-3, EN 60950-4  
 EN 60950-5, EN 60950-6  
 EN 60950-7, EN 60950-8, EN 60950-9

## Final Notes

This manual is intended exclusively for use by qualified technicians performing installation. None of the information provided here should be considered relevant to the end user.

The installer must demonstrate the correct operation of the automation to clients, including the use of the manual release cable.

Be sure to inform the owner about the importance of regular and thorough maintenance, particularly regarding routine checks of safety and reversal devices.

Model	UPPER 3000	UPPER 3000	UPPER 3900
Power	90 W	90 W	90 W
Force	20 N	20 N	20 N
Gate Area / Weight	2.9 m / 29 Kg	2.9 ft / 29 lb	2.7 ft / 27 lb
Voltage	120-240VAC 50/60Hz		
Light Duration	5 minutes		
Operating Temperature	- 0 ~ 100°F		
Relative Humidity	<30%		
Radio Frequency	433.92 MHz		
Encoding	Rolling code		
Control Power	3 V Battery		
Warning Light	LED, 12VDC		

# Kit Components

Item	Quantity
Automation System	1 Unit
Release Track with Manual Override	1 Unit
Controls	Units
Mounting Bracket for Gate Installation	1 Unit
Mounting Bracket for Door Frame	1 Unit
U-Shaped Brackets	Units
Manual Release Rope	1 Unit
Rope Hangers	1 Unit
Straight Arm	1 Unit
Curved Arm	1 Unit
Mounting Kit	1 Unit

# General Errors / Codes

Code	Error	Possible Causes	Suggested Solutions
<b>E0</b>	High / Low Voltage	1. Battery voltage is too low. 2. Power outlet voltage is too high or too low.	1. Replace with a new battery 2. Check the outlet voltage
<b>E1</b>	No signal detected by main sensor	1. Door body is blocked or too heavy 2. Motor is faulty 3. Main sensor is disconnected, or the part is damaged; motor sensor feedback gear or wiring is faulty	1. Replace with a more powerful product 2. Replace the motor 3. Replace the sensor
<b>E2</b>	No signal detected by secondary sensor.	The secondary sensor is either not connected, damaged, or the motor sensor feedback gear is malfunctioning.	Replace the motor. Replace the sensor.
<b>E3</b>	Communication error between the primary and secondary sensors	The wires for the primary and secondary sensors are swapped	Check that the wiring between the primary and secondary sensors is correct
<b>E4</b>	Man-door terminal open circuit	1. The man-door is open 2. The man-door detection circuit is malfunctioning	1. Close the access door 2. Short the man-door terminal and inspect the signal terminal
<b>E5</b>	Unknown motor model	Abnormal motor gear	Replace the motor gear
<b>E6</b>	Door blocked during opening	1. The door is too heavy 2. Resistance detection circuit malfunction	1. Switch to a higher-capacity product 2. Replace the main board 3. Inspect the door's condition
<b>E7</b>	Motor overcurrent	Damaged PCBA	Install a new PCBA
<b>E8</b>	Main line current is too low	Input voltage is currently too low	1. Check the outlet voltage 2. Door may be too heavy or track might be faulty 3. Replace the battery with a new one
<b>E9</b>	Motor jammed	High current caused by continuous operation	Check the motor for damage

# WiFi Connection Guide

## Important – Read This First

Before activating the WiFi feature, make sure the garage door opener's open and close positions are set.

Make sure your router, smartphone, and device are as close to each other as possible. Ensure your Wi-Fi network has 2.4G enabled, and turn on Bluetooth.

Only one user account can be used to control the garage door opener. Make sure the garage door opener hasn't already been linked to a different account. However, please note that the main account can invite family members in the app to share control.

## Please reset the Garage Door Opener before following the instructions below.

Press and hold the "DOWN" button on the opener until "o" appears on the display. Next, press the "UP" button until " " shows up, then press "SET" to confirm the reset is complete.

## Setup

Download the "Smart GDO" app to your smartphone from Google Play (for Android) or the App Store (for iOS).

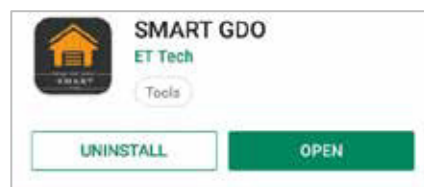


Fig. 4

Or use your smartphone to scan the QR code. Tap the upper right corner to open it in your browser and download the app.



Fig. 5

Fig. 6

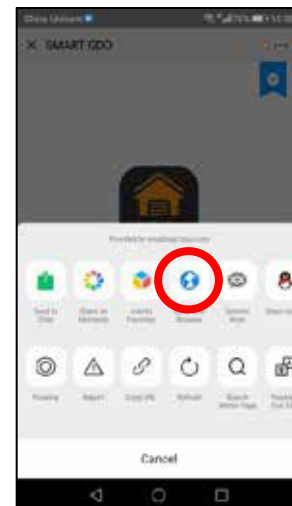


Fig. 7

Open the app and follow the steps to create a new account. If you already have an account, just log in.

- ) Tap the "Sign Up" button
- ) Enter your mobile number
- ) Tap the "Get Verification Code" button

- ) Enter the code you received on your mobile phone
- ) Set a password

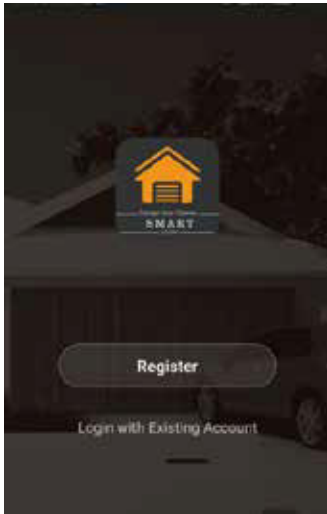


Fig.



Fig. ^

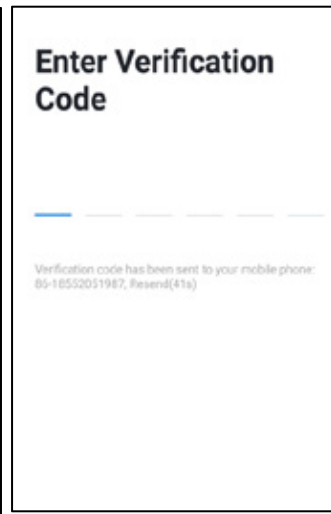


Fig. ~

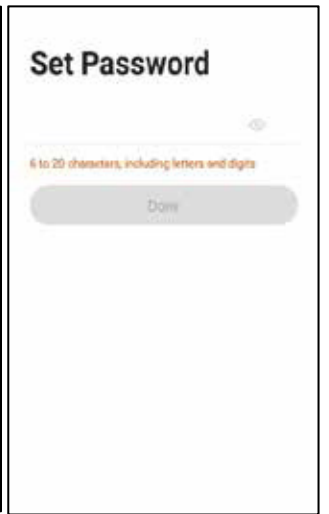


Fig.

” Tap "Add Device" and select "Garage," then press the "Confirm rapid indicator blinking" button.

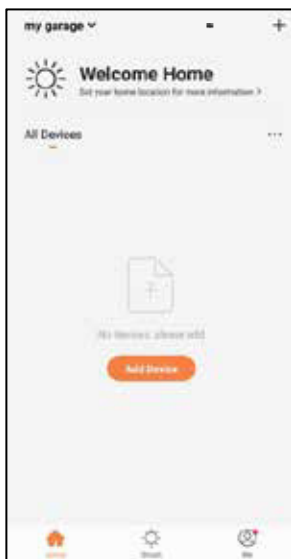


Fig. ~



Fig. °

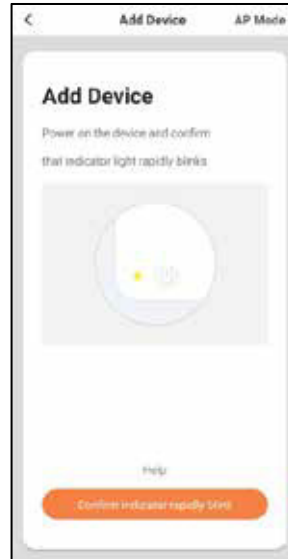


Fig. °°



Fig. °

Select the correct WiFi network, enter your password, and please don't tap "Confirm" until you've finished the next step.

. Garage Door Opener WiFi Setup Press and hold the 'DOWN' button on the garage door opener until the LED shows the number '0' (see FIG °). Press the 'UP' button to choose a setting. ° puts the device into WiFi connection mode (see FIG °). ° resets the WiFi. Press 'SET' to start the WiFi connection.

Once "FF" appears on the display and the dot keeps blinking, the garage remote is connecting to WiFi.

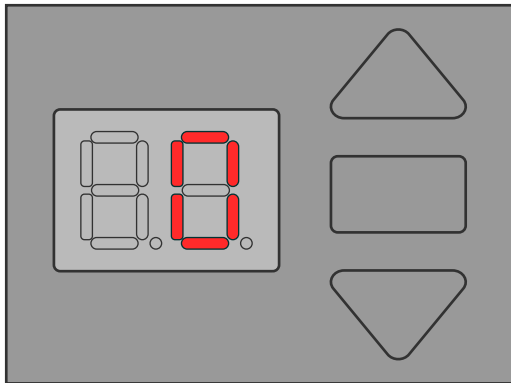


Fig. 2

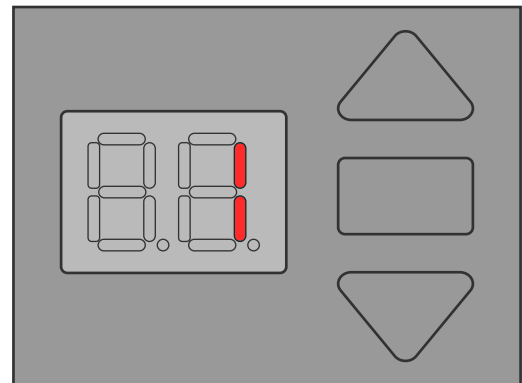


Fig. B

^ Tap the "Confirm" button (see Fig. 2) in the app. The opener will then link up to your network (see FIG 2). This process may take a few minutes. Once it's connected, tap "Done" (see FIG 2).

Only one account can be linked to an automation.

If the connection doesn't work (see FIG 2), repeat these steps to try again.



Fig. A

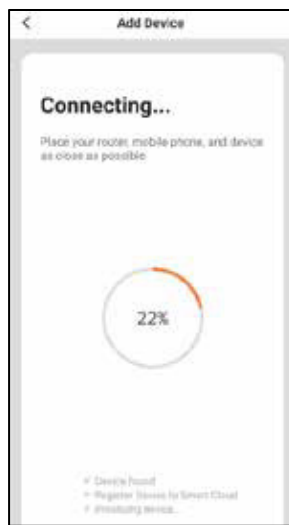


Fig. C

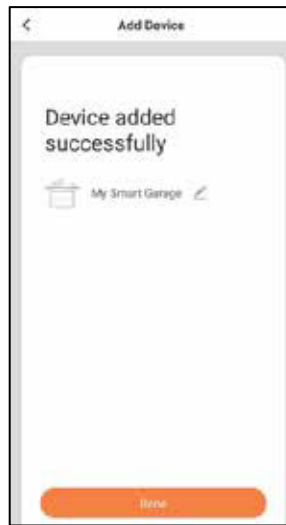


Fig. D

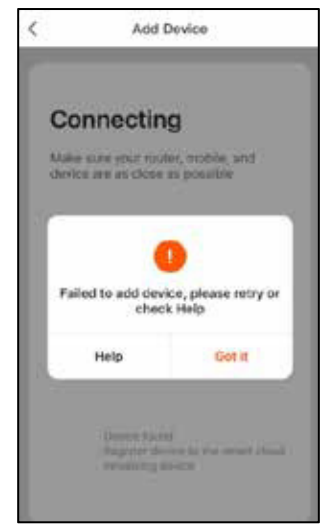


Fig. A

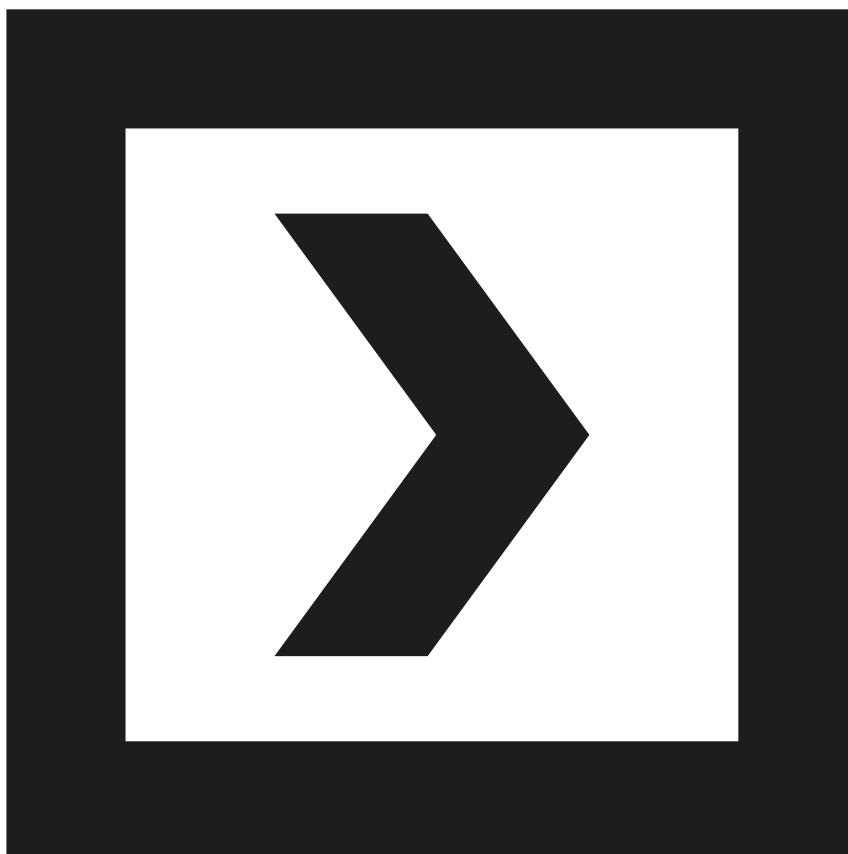
Option 2: Remove device from the app. Tap "Remove device" to delete the opener's details from your original account, keep the garage door opener powered on with WiFi connected, and then reconnect the opener to the new account step by step.

Option 3: Reset the garage door opener

If there's no network connection, restore the garage remote to factory settings.

Hold down the "DOWN" button on the opener until "o" appears on the display, then press "UP" until " " shows up. Finally, press "SET" to finish the reset process.

All connected devices will be removed.



**Daportas Automatics, Ltd.**

1691 Industrial Street  
4750-841 Barcelos, Portugal

+351 253 891 418  
contact@daportas.pt

**daportas.com**  
**dautomatic.com**